

Instructions for installation and use of the

Vaillant Geyser[®]

On installation please
hand this pamphlet
to your customer

All our appliances should
be installed by qualified
fitters only, who will be
responsible for the obser-
vance of all existing na-
tional and/or fitting instruc-
tions and regulations.

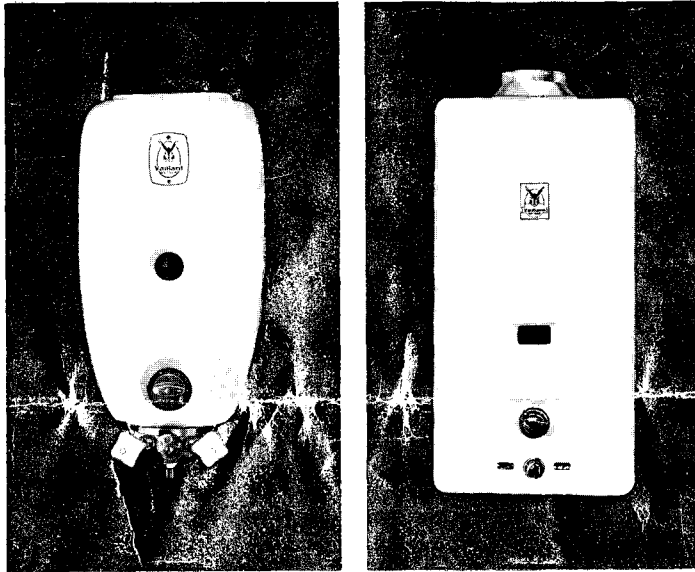

CONTENTS

Page	2	Installation
Pages	3—4	Dimensions
Page	5	Technical data
Page	6	Removal and replacement of front cowling
Pages	6—7	Adjustment of appliance
<hr/>		
Pages	10—11	Maintenance — Trouble shooting
Pages	12—13	Appliances for low water pressures (tank supply)
Page	14	Boiling water heater



Installation

MAG 125/3 town gas and natural gas, MAG 125/1 bottled gas

Gas

a) town gas and natural gas
the water heater is provided either with a gas connection for exposed installation (No. 95-0108) or concealed installation (No. 95-0107).

b) bottled gas
these appliances are provided with a thread coupling R 3/8".

Water

The above mentioned water heaters are provided either with water connections for concealed installation (No. 95-0054) or exposed installation (No. 95-0038). It is also possible to connect remote warm water taps. Use 10 x 12 mm copper tube.

Flue gases

Standard equipment: flue cap picture No. 13 (see page 3)
If the sink heater is installed in a relatively small room and/or connected to a shower, a draught diverter should be fitted and connected to a flue pipe (accessory No. 29).

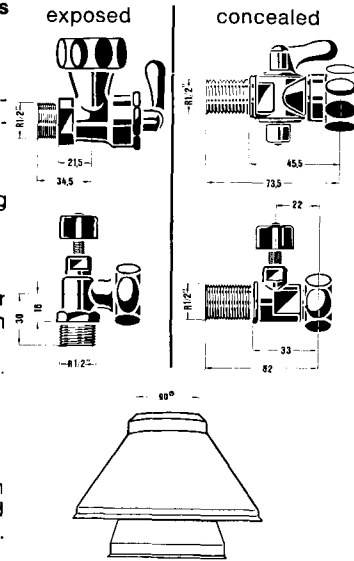

MAG 250/6 — 325/6 — 400/6 town gas and natural gas, MAG 250/6B — 325/6 B — 400/6 B bottled gas (LP)

Gas

a) town gas and natural gas
the appliances are provided with 3/4" (MAG 250/6) and 1" (MAG 325/6 — 400/6) gas connection for exposed installation (see page 4)

b) bottled gas:
the appliances are provided with thread connection R 1/2".
(see page 4)

Water

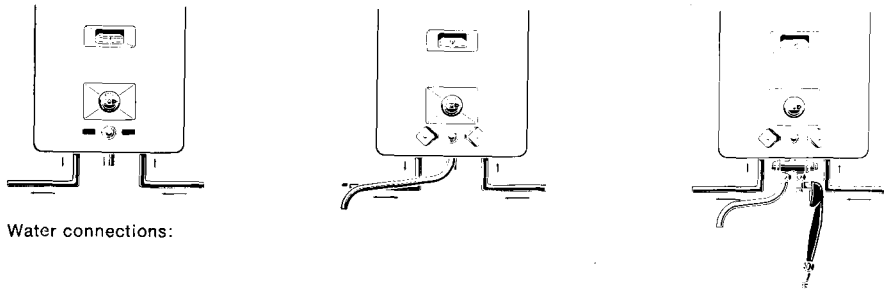

Water connections:

accessory No. 501/1
for multipoint
operation only

accessory No. 204/1
for direct delivery by
swing spout and
remote tapping

accessory No. 304/1
for direct delivery
through switch cock,
with hand shower and
swing spout and
remote tapping

Flue gases

All bath heaters **must** be connected to a flue. Dimensions see page 4.

MAG 125/3 Town Gas
Natural Gas

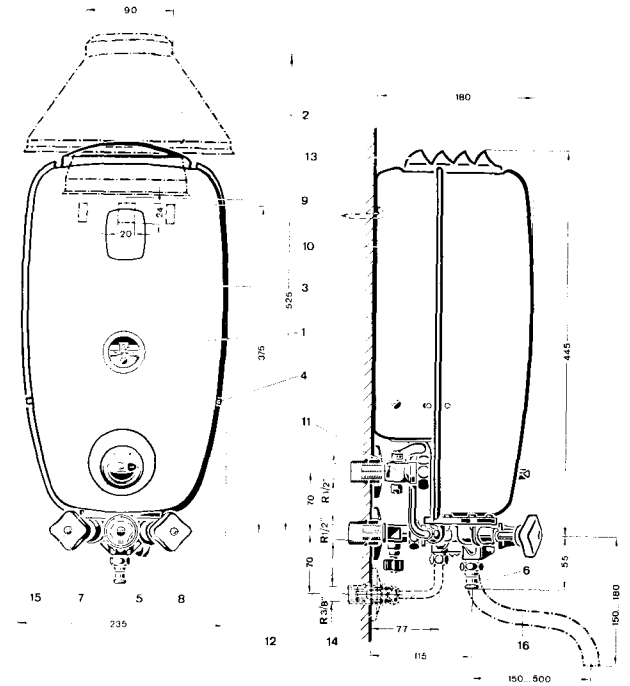

Propane/Butane
MAG 125/1 B

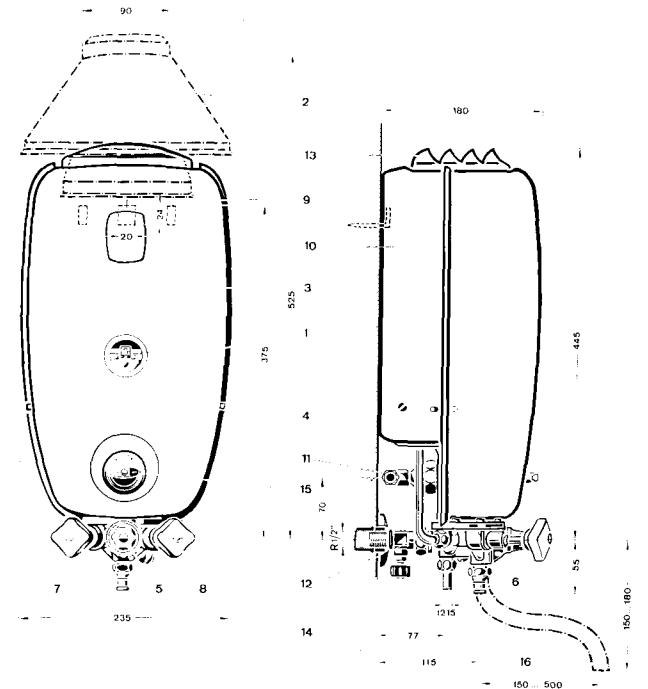

MAG 250/6 R — 325/6 R — 400/6 R
 MAG 250/6 M — 325/6 M — 400/6 M
 MAG 250/6 B — 325/6 B — 400/6 B

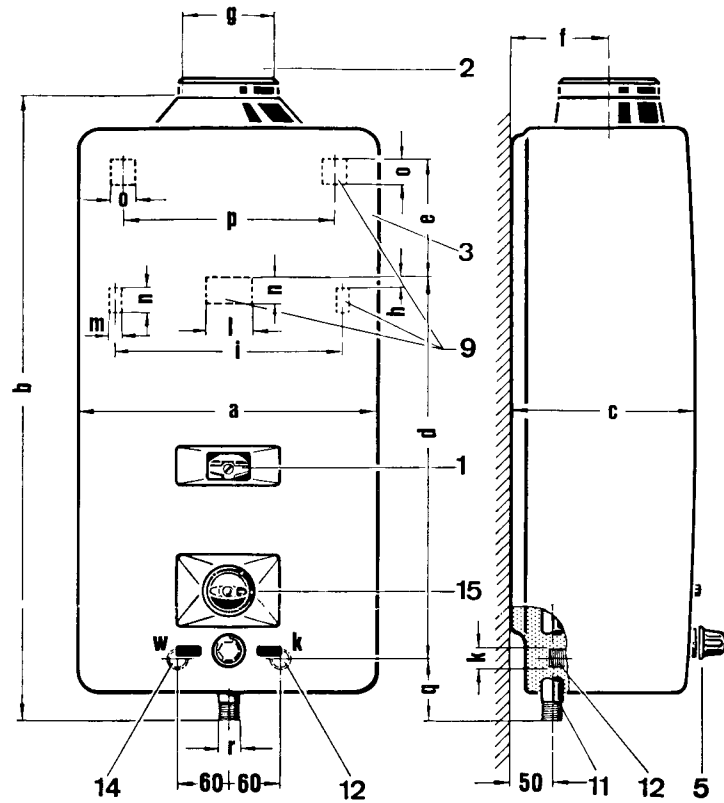

- 1 pilot burner
- 2 draught diverter
- 3 cowling
- 4 fastener for cowling
- 5 temperatur selector knob
- 6 spout
- 7 hot water tap
- 8 cold water tap
- 9 mounting hole
- 10 back panel
- 11 gas connection
- 12 cold water connection
- 13 flue cap
- 14 warm water connection
- 15 gas valve
- 16 swing spouts
 No. 21=150 mm = about 6"
 No. 22=250 mm = about 10"
 No. 23=350 mm = about 14"
 No. 24=500 mm = about 20"

Type	a	b	c	d	e	f	g	h	i	l	m	n	o	p	q	k	r town + natur. gas	r Lp Gas	w
MAG 250/6	352	730	227	450	135	112	110	15	265	55	15	30	30	250	70	R 1/2"	R 3/4	R 1/2"	R 1/2"
MAG 325/6	422	850	232	540	155	106	130	15	325	55	15	30	30	320	70	R 1/2"	R 1"	R 1/2"	R 1/2"
MAG 400/6	422	925	232	540	155	106	130	15	325	55	15	30	30	320	70	R 1/2"	R 1"	R 1/2"	R 1/2"

Technical data

Town Gas

Type	MAG	125/3	250/6	325/6	400/6	
Rated output	500	1000	1300	1600		BTU per min
	125	250	325	400		kcal per min
Rated input	600	1200	1550	1900		BTU per min
	150	300	390	475		kcal per min
Gas consumption (at c.v. of 450 BTU/cu. ft. and 60 °F, 30" HG—4000 kcal/m³ and 15,5 °C 762 mm HG)	1.4	2.8	3.7	4.7		cu. ft. per min
	40.0	80.0	104.0	128.0		litres per min
Output of water 40 °F (22 °C) rise MAG 400 50 °F (27 °C) rise	1.25	2.5	3.25	3.2		Imp. gal. per min
	5.7	11.4	14.8	14.5		litres per min
Output of water 100 °F (55 °C) rise	0.5	1.0	1.3	1.6		Imp. gal. per min
	2.3	4.6	5.9	7.3		litres per min
Minimum water pressure	11.4	15.6	21.3	25.5		P.S.I.
	0.8	1.1	1.5	1.8		kg/cm²
Maximum water pressure	5.0	4.3	5.0	6.4		P.S.I.
	0.35	0.3	0.85	0.45		kg/cm²

Propane/Butane

Type	MAG	125/1 B	250/6 B	325/6 B	400/6 B	
Rated output	500	1000	1300	1600		BTU per min
	125	250	325	400		kcal per min
Rated input	600	1200	1550	1900		BTU per min
	150	300	390	475		kcal per min
Gas consumption	0.85	1.70	2.20	2.70		kg/hr.
	1.89	3.70	4.80	5.90		pound/hr.
Output of water 40 °F (22 °C) rise MAG 400 50 °F (27 °C) rise	1.25	2.5	3.25	3.2		Imp. gal. per min
	5.7	11.4	14.8	14.5		litres per min
Output of water 100 °F (55 °C) rise	0.5	1.0	1.3	1.6		Imp. gal. per min
	2.3	4.6	5.9	7.3		litres per min
Minimum water pressure	11.4	15.6	21.3	25.5		P.S.I.
	0.8	1.1	1.5	1.8		kg/cm²
Maximum water pressure	5.0	4.3	5.0	6.4		P.S.I.
	0.35	0.3	0.3	0.45		kg/cm²

Natural Gas

Type	MAG	125/3 M	250/6 M	325/6 M	400/6 M	
Rated output	500	1000	1300	1600		BTU per min
	125	250	325	400		kcal per min
Rated input	600	1200	1550	1900		BTU per min
	150	300	390	475		kcal per min
Gas consumption	18.0	36.0	47.0	58.0		litres per min
	0.64	1.28	1.76	2.16		cu. ft. per min
Output of water 40 °F (22 °C) rise MAG 400 50 °F (27 °C) rise	1.25	2.5	3.25	3.2		Imp. gal. per min
	5.7	11.4	14.8	14.5		litres per min
Output of water 100 °F (55 °C) rise	0.5	1.0	1.3	1.6		Imp. gal. per min
	2.3	4.6	5.9	7.3		litres per min
Minimum water pressure	11.4	15.6	21.3	25.5		P.S.I.
	0.8	1.1	1.5	1.8		kg/cm²
Maximum water pressure	5.0	4.3	5.0	6.4		P.S.I.
	0.35	0.3	0.35	0.45		kg/cm²

The above mentioned data apply to a C. V. (15,5 °C. 762 mm Hg = 60 °F, 30" Hg) of
 2550 BTU/cu.ft. = 21600 BTU/pound = 22700 kcal/m³ = 12000 kcal/kg for Propane
 3450 BTU/cu.ft. = 21600 BTU/pound = 29800 kcal/m³ = 12000 kcal/kg for Butane
 995 BTU/cu.ft. = 8850 kcal/m³ for Methane

Appliances for extremely low water pressure see pages 12 and 13

1. Removal of Front Cowling

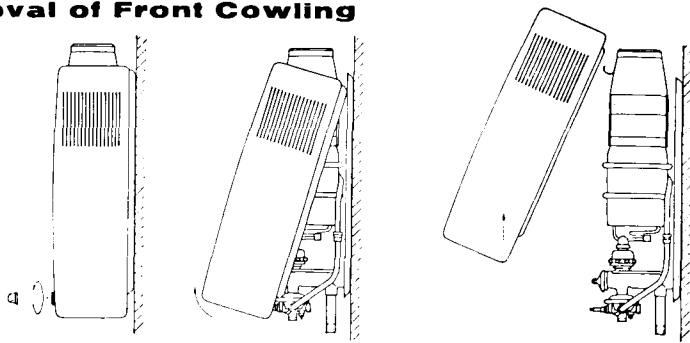

- a) Pull off temperature selector knob and tap knobs where fitted. Loosen locking nut with a left turn, but do not remove from cowling
- b) Remove cowling as illustrated
- c) Lift off cowling from hook on draft diverter.

2. Replacement of cowling

Reverse the procedure. Please ensure that cowling fits into the lips of the backplate. Hook on draft diverter has an adjustable screw for cowling adjustment.

Adjustment of appliance

GAS (town gas and natural gas appliances only)

Pilot burner. Turn knob of gas valve to position * or I (in case of bimetal-protected heaters: I-marked, in case of thermocouple protected heaters *-marked) light on, adjust pilot flame by adjusting screw 4 (see page 7). The pilot flame is divided into ignition- and control-flames. Whilst both the right and left flames have to ignite the burner ramps the central flame, the control flame, has to heat up the bimetal or thermo-couple. When the outer flames reach the burner bars as shown on the attached picture the controlflame has reached its required length.

Burner. Burner flames ignite automatically when the warm water tap is opened and extinguish when the tap is closed.

Adjustment of the burner:

a) according to **rated output:**

only possible when the water pressure corresponds to or exceeds the min. water pressure. Turn knob of temperature selector 6 to the right all the way and open warm water tap completely. Adjust the flow of gas by screw 5 (on appliances **without** volumetric gas governor) until a rise of temperature (rise of temperature = outlet temperature minus inlet temperature) of about $93-95^{\circ}\text{F} = 52-55^{\circ}\text{C}$ is obtained. Before checking the water temperature let the water run for at least a minute.

Appliances which have been in use for some time should be adjusted only according to rated input, since due to calcification, soot or other residues their performance may have been impaired.

b) according to **rated input:**

this should be done only if the C. V. is known.

rated input in kcal/min = gas consumption in l/min x C. V. in kcal/m³

or

rated input in BTU/min = gas consumption in cu.ft./min x C. V. in BTU/cu. ft.

Read gas consumption on gas index and, taking into consideration the available heating value, test whether the correct consumption (see following chart) is set. For greater accuracy it is advisable to check the amount of gas used in 3 minutes:

$\frac{\text{gas amount read}}{3} = \text{gas consumption in cu.ft./min (l/min)}$

Gas regulation on appliances without volumetric gas governor (MAG 125/3, MAG 250/6 or MAG 325/6). After removing the cap on the right side of the gas valve turn the gas adjusting screw (turn to right = less gas, turn to left = more gas). Then replace the cap and seal it.

	Town gas							Natural gas	BTU/cu.ft. kcal/m ³
	390 3500	420 3750	450 4000	480 4250	510 4500	540 4750	570 5000	335 8850	
(60 °F and 30" Hg C. V. 15.5 °C and 762 Hg)									
gas consumption MAG 125/1—3	1.66 47	1.55 44	1.48 42	1.38 39	1.31 37	1.24 35	1.17 33	0.67 19	cu.ft. per min l per min
MAG 250/5—6	3.35 95	3.11 88	2.93 83	2.79 79	2.65 75	2.47 70	2.33 66	1.31 37	cu.ft. per min l per min
MAG 325/5—6	4.31 122	4.03 114	3.81 108	3.6 102	3.43 97	3.25 92	3.04 86	1.73 49	cu.ft. per min l per min
MAG 400/6	5.37 152	5.01 142	4.73 134	4.45 126	4.2 119	3.96 112	3.78 107	2.12 60	cu.ft. per min l per min

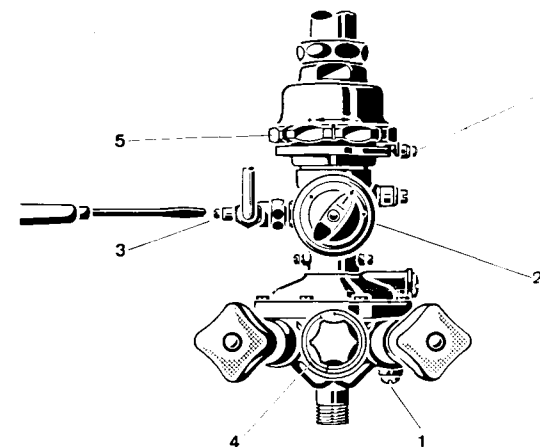

Appliance with built-in volumetric gas governor (MAG 125/3 R, 250/6 R, 325/6 R 400/6 R) do not require regulation as they are regulated when leaving the works.

WATER

The heater can be used up to a water pressure of 210 P.S.I. (15 kg/cm²). It is equipped with an automatic water governor which makes water adjustment unnecessary. Maximum outlet temperature (the appliances can be delivered either for a rise of temperature $108 - 107^{\circ}\text{F} = 60 - 65^{\circ}\text{C}$, or for a rise of temperature $90 - 100^{\circ}\text{F} = 50 - 55^{\circ}\text{C}$) is obtained by turning knob of temperature selector "4" to the right all the way. When turning knob all the way to the left the minimum outlet temperature (temperature rise $36 - 45^{\circ}\text{F} = 20 - 25^{\circ}\text{C}$) is obtained. For intermediate temperatures turn knob anywhere between above limits.

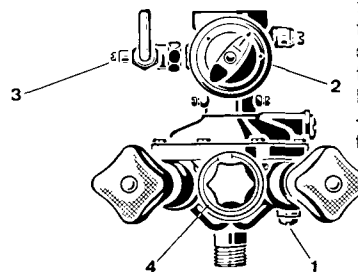

Users instructions

Taking into operation (for thermo-couple protected heaters only)

When starting the heating unit, the following sequence at the rotation handle of the gas switch has to be taken into consideration:

Shut-off position

The indication (I) at the rotation handle shows to white point (●) on the handle ring. Pilot and main gas valve are closed.

Ignition position

Turn rotation handle up to the fixing point (passed the ignition position *) to the left and keep in this position about ten seconds after having ignited the pilot flame. In this time the thermo-current is generated. This thermo current holds the rotation handle and keeps the pilot valve open. In case the rotation handle returns to the shut-off position (●) the ignition procedure must be repeated. If the heating unit has been out of operation for a longer time, it may be that air has diffused into the pilot pipe. In this case it lasts some second more until combustible gas reaches the pilot burner head.

Operation position

Turn rotation handle from the ignition position to the right to operation position (▲). Now the main gas valve is opened and the heating unit is ready for operation.

Taking out of operation

The unit is taken out of operation — as far as the gas is concerned — by turning the rotation handle to the right and to shut-off position. Naturally, to take the unit out of operation only temporarily, the rotation handle should be only turned to the left to ignition position. From the shut-off position the unit can only be taken into operation again after the mechanism of the thermo electric pilot safety device has returned into the original position (locking device).

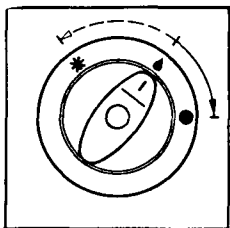
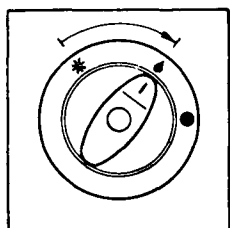
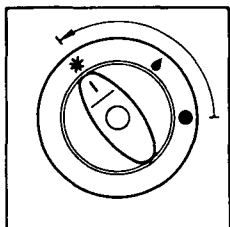
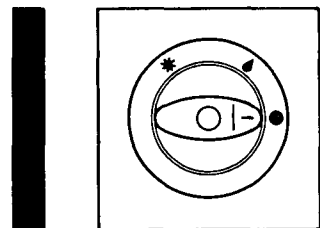

Lighting of the heater (for bimetal protected heaters only)

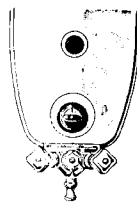

"Off" position

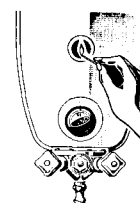

Turn gas switch to the left one notch, light pilot flame

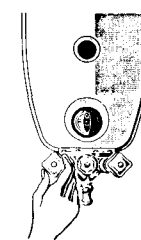

After 30 secs. turn gas switch to the left one notch further, then open warm water tap

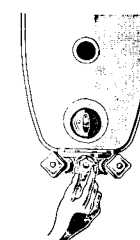

Temperature selector knob
a) turned to the right:
very hot water
b) turned to the left:
hot water

How to shut off the heater

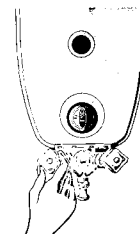

Shut off warm water tap, the heater is still ready for use

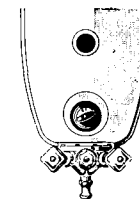

Turn gas switch one notch to the right, main gas supply is shut off, pilot flame is still burning

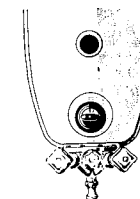

Turn gas switch to the right until complete stop: "Off" position

Maintenance of the heater

It is easy to clean the exterior of the heater, because the smooth enamelled sheet metal body completely encloses all vital components, and there are no corners where dust or dirt could collect. During the operation of the heater dust and combustion particles deposit on the heat exchanger, burner, etc. These deposits should be removed by a qualified fitter during periodical servicing, prior to checking and adjusting appliance for correct and efficient operation.

A hint how to reduce calcification of the heater

After every hot water tapping first turn gas switch one notch to the right, in order to show off the gas supply, and only when cold water begins to run, close the tap. By doing this, you will also economise on gas.

How to prevent frost damage

In case of room temperatures below 32 °F (0 °C), the heater should be drained as follows

1. Close water shut-off valve (C).
2. Open **all** hot and cold water taps.
3. Turn temperature selector knob (A) to the left until stop.
4. Unscrew drain screw (B) and after complete drainage tighten screw again (see illustration).

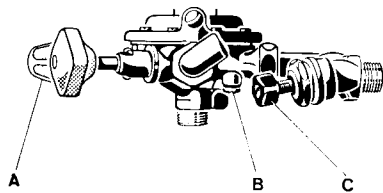
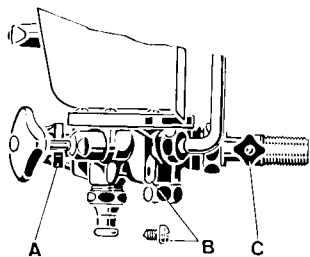

Maintenance

Every Heater should be cleaned periodically, depending upon the frequency and duration of its operation, but never less than once a year. This inspection and servicing should be carried out by a qualified plumber. Proceed as follows:

Remove heat exchanger and rinse laminas in hot water and detergent, brush, etc. Take care not to bend laminas, otherwise straighten with pliers.

Check ignition of burner. When opening warm water tap, the burner should be ignited by the pilot flame without undue delay.

In case of calcareous (hard) water decalcification is required once or twice a year (depending upon frequency of usage) otherwise the heater may get damaged. After the ignition flame has been switched off, a period of up to 1.5 minutes may elapse before the bimetal spring straightens out enough so that it is no longer in contact with the top of the ignition valve pin or the thermo-couple in cooled down to close down the main gas valve of the gas section. Distance between top of ignition valve pin and bimetal spring, when cold (about 5 minutes), should be 1 mm (0.04 in.). Adjust bimetal spring by bending or replace it. The top of the ignition valve pin must protrude at least 0.5 mm (0.33 in.) over the burner. The pin of the valve should be free (test by pressing lightly).

These figures are only valid for bimetal-protected heaters:

town gas (multigas-burner)
natural gas
bottled gas (bath heaters)

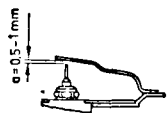

MAG 125/3
MAG 250/6 - 325/6 B

town gas (flat burner)

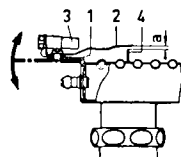

250/5 - 325/5

bottled gas
(sink-heaters)

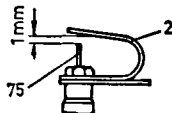

MAG 125/1 B

Trouble Shooting

When it becomes necessary to lubricate moving parts, we strongly recommend the use of special Vaillant Grease.

Loss of efficiency can be caused by:

(Town gas — Natural gas)

- a) Gas pipe too small.
- b) Gas meter too small. Replace.
- c) Gas pipe or gas strainer clogged. Remove heater assembly, disassemble gas strainer and clean. Before reassembly blow out gas pipe. Water in gas pipe. Drain gas pipe or preferably change the routing of same.

(Bottled gas)

- a) Gas pipe is too long or too small a bore — larger sized pipe required.
- b) Gas pipe is obstructed — clogged, pinched etc.
- c) Gas feed pressure too low. Check pressure at regulator outlet — gas filter may be clogged-gas feed pressure to burner is below required value.

Yellow flames (Bottled gas)

As supplied, burners on Vaillant Water Heaters are correctly set for Butane, Propane or any mixtures. If yellow tips appear, check that burners are undamaged and gas feed pressure is correct. Laminas clogged.

Unsatisfactory ignition can be caused by

- a) insufficient opening of the pilot safety valve.
- b) too low water pressure.
- c) clogged water filter (clean it).

Water temperature variation from correct setting may be due to:

Influence of inlet water temperature (summer — winter).

Ignition valve does not open sufficiently; Bimetal spring bent or worn. Soot on bimetal spring.

Calcification: Decalcify heat exchanger, dismantle water outlet and remove lime. Water valve should be rinsed thoroughly with water.

If necessary rinse in hydrochloric acid, solution 1:5 (pour acid in to water!) Handle with utmost care to avoid contact between acid and chrome surface.

Burner does not ignite or extinguishes when hot water tap open. Water pressure too low or dropping during tapping: Please note "Technical Data" (see page 5). To check turn temperature-selector knob to right all the way. Heater will also function properly on low water pressure, if temperature selector is adjusted to higher outlet temperature. Clogged water strainer. Remove heater assembly, disassemble water strainer of water valve clean and assemble.

Pipes or valves in the hot water system are too narrow. Replace pipes or valves.

Flames continue burning when hot tap closed:

Air in the hot water system. Typical sign is burner ignition, when main gas valve is open and cold water is tapped at other taps. Release air because it may be dangerous to heater in case of repeated opening of taps. (Air pocket may develop due to incorrectly installed or unused warm water pipes).

Slow ignition device incorrectly installed. Straight slot must be visible. Burner flames extinguish completely 1—1.5 secs. after the warm water faucet has been turned off.

(For further servicing instruction require Vaillant Service Manual.)

Adjustment of appliance:

Water

Adjust the appliance only in the following sequence:

Before adjusting open warm water tap 24 fully.

Adjust by regulating the screw 6 (125/1-3 N or the cock 7 (250/6 — 325/6 N) completely. If after adjustment of gas, the hot water outlet temperature is too low, the water quantity can be throttled by turning the regulating cock until the outlet temperature required is obtained. Please take care that the temperature is not increased by more than 90 °F (50 °C) in order to avoid a shut off of the burner gas by the water deficiency valve in case of temporary pressure fluctuations.

125/1-3 N

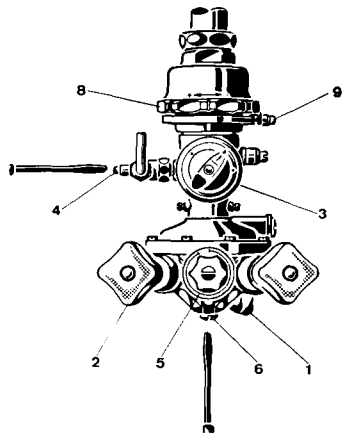

If there is too much water flowing out adjust the regulating cock no. 6 to obtain:

an outflowing water quantity of 2.3 l/min = 0,5 Imp Gal./min. (Turn temperature selector knob to the right until stop).

250/5 — 325/5-6 N

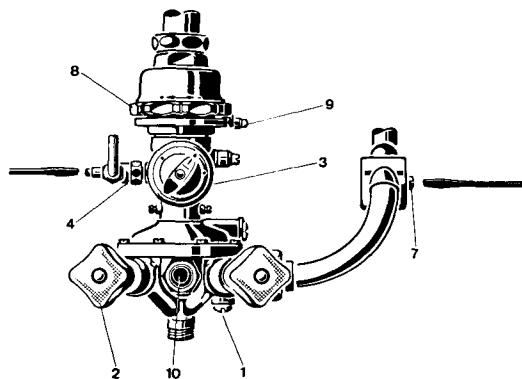

from the **MAG 250/6 N** an outflowing water quantity of 5 l/min = 1,1 Imp. Gal./min minimum

from the **MAG 325/6 N** an outflowing water quantity of 6,5 l/min = 1,45 Imp. Gal./min minimum

If the water pressure should change adjust again.

The slow ignition valve is screwed in to each appliance. If the ignition of the burner flames takes place too slowly this slow ignition valve should be taken out.

	MAG 125/1-3 N	MAG 250/5-6 N	MAG 325/5-6 N	
Minimum water quantity temperature rise 90 °F (50 °C)	0.5	1.1	1.45	Imp. Gal./min litres/min
	2.3	5.0	6.5	
Nominal water quantity temperature rise 40 °F (22 °C)	1.25	2.55	3.3	Imp. Gal./min litres/min
	5.7	11.5	15	
Nominal water pressure	5.0	6.8	11.0	P.S.I. kg/cm ²
	0.35	0.48	0.78	
Minimum water pressure	1.35	1.2	1.49	P.S.I. kg/cm ²
	0.095	0.085	0.105	

Vaillant MAG-K 125/... for tapping of boiling water

This appliance corresponds technically to the MAG 125/... appliance for normal water pressure. The only difference is the water section. Thus a normal water heater MAG 125/... can be transformed by exchanging the complete water section to a MAG-K 125/... boiling type.

The tapping of boiling water is due to the special construction of
the temperature selector
the warm water tap unit

During the tapping of boiling water the temperature selector must be turned to the red mark and the warm water tap must be opened completely.

A special valve unit prohibits the outflow of boiling water to remote taps. When the warm water tap is completely closed, a by-pass is opened by the last running regulation for an additionally water quantity. Thus the maximum temperature rise at remote taps cannot exceed $50\text{ }^{\circ}\text{C} = 100\text{ }^{\circ}\text{F}$.

For the direct tapping of boiling water a swivel spout is generally included to the MAG-K 125/... appliances; accessory no. 21 = 150 mm = about 6".

Technical data

Rated output	125 kcal/min 500 BTU per min
Output of water $55\text{ }^{\circ}\text{C} = 100\text{ }^{\circ}\text{F}$ rise	2.3 litres per min 0.5 Imp. gal. per min
Output of water (boiling) about	1.3 litres per min 0.3 Imp. gal. per min
Minimum water pressure (boiling temp.)	0.5 kg/cm ² 7.1 P. S. I.